

### **Dismantling the trigger mechanism.**

REFER TO THE DIAGRAM SHOWING DETAILS OF TRIGGER ASSEMBLY.

Before dismantling the trigger mechanism take note of how the springs are positioned to aid reassembly.

The trigger mechanism is removed from the action as a complete unit by tapping out the two end plug pins (3358). To dismantle the mechanism, tap out the safe toggle pin (3371), and withdraw the safe toggle (3314) from the top of the cage. Tap out the main sear axis pin (3370), then remove the main sear (3363) and mainsear spring (3374) from the front of the cage. Tap out the intermediate sear axis pin and remove the intermediate sear (3337) and its spring (3373) from the rear of the cage. Tap out the trigger axis pin and remove the trigger blade (3335) and trigger block (3340) assembly from the underside of the cage. Unscrew the trigger load screw (3377) from the cage and remove the secondary sear spring (3376). Tap out the trigger stop pin (3371) - the trigger stop (3372) and secondary sear (3352) can then be removed from the underside the cage. It is unnecessary to remove the stock screw block (3352), however if desired, tap out its two retaining pins (3371).

Reassemble in the reverse order. Insert the action pins from the right handside of the cage and use the relevant pins to position the trigger stop, secondary sear spring and main sear spring in the right hand side of the cage.

When refitting the trigger mechanism to the action, ensure the safe toggle engages in the safe slot and refit the two end plug pins.

To reset the trigger refer to the section TRIGGER ADJUSTMENT.

Check that the action functions satisfactorily before re-assembly into the stock.

# THE LONGBOW

## OWNER'S MANUAL SERIES 2 MODELS



READ THIS MANUAL BEFORE  
USING YOUR NEW AIRGUN

### THE FAMOUS NAME IN AIRGUNS WEBLEY AIR RIFLES

Universe House, Key Industrial Park, Planetary Road, Willenhall,  
West Midlands WV13 3YA

Telephone: +44 (0)1902 722 144 Fax:+44 (0) 1902 722 880  
Service Line: +44 (0) 1902 738 070

## GUARANTEE

The Webley Longbow air rifle is fully guaranteed against faulty workmanship and defective materials for a period of three years from the original date of purchase provided it has not being misused or tampered with in any way. Should you experience problems with your rifle please consult the dealer from whom it was purchased. This guarantee does not affect your statutory rights.

## THE LAW

**KNOW THE LAW ON AIRGUNS AND OBEY IT.  
ACT RESPONSIBLY, ACT SAFELY, AND THEN ENJOY YOUR  
SHOOTING!**

## WARNING!

Serious damage may occur to yourself or your rifle if the barrel is allowed to snap shut under the influence of the mainspring. Please ensure that your finger is well away from the trigger when cocking the rifle. Removal of the main spring must be carried out by a qualified repairer. Read the instructions carefully before attempting this procedure to avoid injury.

## RUNNING-IN

During the running-in period, after the first few hundred rounds, check the tightness of the stock fixing screws, and periodically thereafter. Failure to keep the stock screws tight can result in broken screws. The correct tightening torque is 0.35 Kg m (2.5 lb.ft.) for the front stock screws (3383). 0.35 Kg m (2.5 lb.ft.) for the guard screws (3387 & 3385) Use WEBLUBE for lubrication of air rifles, as directed in this manual.

**OUR POLICY IS ONE OF CONTINUAL IMPROVEMENT. WE RESERVE  
THE RIGHT TO MODIFY THE SPECIFICATIONS OF THESE  
PRODUCTS WITHOUT PRIOR NOTICE.**

Fig.8.



Oil the piston assembly, then wipe the front faces of the seal and piston dry. Clean and lightly lubricate the body tube bore - do not over lubricate. Refit the piston assembly to the body tube assembly, ensuring their loading lever slots are aligned with one another.

### Important Note:

The lip of the piston seal is an interference fit in the body tube. As the piston assembly is pushed down the body tube, take care not to damage the piston seal lip as it passes over body end plug pin holes, safe clearance slot, trigger mechanism slot hidden by the cage and the loading lever slot.

To minimize the risk of damage, deflect inwardly the portion of lip exposed through the holes and slots using a blunt instrument e.g. the blade of a screwdriver (fig.9).

Fig.9.



When reassembling the lock mechanism it is advisable to hold the barrel housing in a vice, using soft clamps or cloth to protect its finish.

Assemble the barrel locking plunger pin approx. 1/8" (3 mm) into its hole on one side of the barrel housing - the pin is a drive fit.

Refit the barrel locking plunger spring and barrel locking plunger to the barrel housing. Compress the barrel locking plunger against the spring pressure until its slot straddles the barrel locking plunger pin hole.

Push the 1/8" (3 mm) diameter drift, now used as a slave peg, through the open end of the barrel locking plunger pin hole to retain the barrel locking plunger spring and barrel locking plunger in the barrel assembly. Drive the barrel locking plunger pin through until it lies centrally within its hole.

This operation will push the slave peg out.

Re-assemble the loading lever to the barrel housing, and then refit the barrel assembly to the body tube, in the reverse order.

### **Piston and Seal Assembly.**

The piston and seal assembly can only be removed when the mainspring, trigger mechanism and loading lever have dismantled from the body tube.

Insert a small screwdriver through the loading lever slot in the body tube, then carefully push or tap the piston (3453) towards the end of the tube taking care not to touch or damage the piston seal (3144). When sufficient piston skirt has emerged, grasp it firmly and pull it right out.

Inspect the piston seal for wear and damage - do not dismantle it from the piston unless renewal is necessary. To remove the old seal, unclip it of the piston location using a screwdriver blade as a lever, alternatively slice through its section with a sharp safety razor blade, penknife or Stanley knife.

Before fitting a new piston seal, first clean, then lubricate the location recess of the piston. Spring the new piston seal over the piston location and push it against the shoulder of the piston, the seal will then automatically into its recess. If necessary, the piston seal may be immersed in boiling water until it becomes sufficiently pliable to clip over the piston (wipe the seal dry before fitting).

Check the seal is located evenly around the piston (fig. 8).

## **USE, CARE AND MAINTENANCE OF THE WEBLEY LONGBOW AIR RIFLE.**

### **SPECIFICATION.**

The Longbow is a spring operated, single shot, break-action air rifles fitted with a precision rifled barrel, primarily suited to waisted lead pellets. The use of steel darts is not recommended. The rifle is available in .177 (4.5 mm), 22 (5.5mm) and .25 (6.35) calibre's.

The LONGBOW has many special design features, which include:

1. A fully adjustable 2-stage trigger mechanism.  
PLEASE NOTE TRIGGER IS FACTORY SET TO 0.9 kg. (2 lbs.)
2. An automatic re-settable safe
3. Adjustable forend jaws to ensure accurate barrel alignment is maintained.
4. A machine-cut dovetail is provided for the fitting of a telescopic sight.
5. A mainspring damper, which eliminates spring vibration
6. Custom style ambidextrous stocks incorporating double cheekpieces and ventilated rubber recoil pad. Available in beech or walnut.
7. Optional screw-in silencers are available.

### **NOMINAL WEIGHTS:**

LONGBOW BEECH (no sights fitted) 3.3kgs (7.3lbs)

LONGBOW WALNUT (no sights fitted) 3.0kgs (6.6lbs)

### **RIFLED BARREL LENGTH:**

ALL MODELS 33cm (13 ins)

### **OVERALL LENGTH:**

LONGBOW  
99cm(39ins)

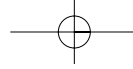

## THE BASIC SAFETY RULES ARE:

1. Treat every rifle as if it is loaded.
2. Never point a rifle at anyone, or allow anyone to point a rifle at you, even if you know it is not loaded.
3. Always carry a rifle so the direction of the muzzle is under control, even if you stumble.
4. Always be sure of your target and what lies behind it before discharging your rifle.
5. Never leave a loaded rifle unattended.
6. Beware of targets that tend to cause ricochets

## OPERATING INSTRUCTIONS

1. With the open hand, sharply tap the muzzle end of the barrel down to open the spring lock. Then using the barrel as a lever, cock the rifle as far as it will go; the trigger sear will be heard to engage with a click. The safe will automatically engage

**N.B.** Keep the forefinger of the supporting hand clear of the trigger whilst cocking the rifle. Also, never allow the barrel to spring back before the sear is engaged nor pull the trigger until the barrel is returned to the closed position.

2. Insert a pellet into the breech of the barrel (fig. 1) and push the pellet with the finger or thumb only until flush with the end. Close the barrel; the spring lock will automatically engage.



Fig.1

the exit hole in the body tube, then pull the end of the lever out of the hole. Remove the barrel housing spacer (2649) and disc washer (2656) from their recesses in the barrel housing.

Fig.6

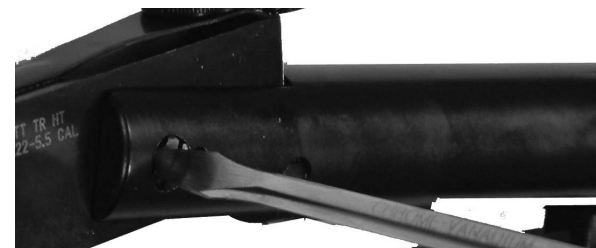

To dismantle the loading lever from the barrel assembly, tap out the loading lever fulcrum pin (2658).

To dismantle the barrel lock mechanism, tap out the barrel locking plunger pin (2869) using a 1/8" (3 mm) diameter drift (fig.7).

Fig.7



Compress the barrel locking plunger spring (2990) by pushing the barrel locking plunger (2989) and withdraw the drift.

Ease the pressure off the barrel locking plunger allowing the plunger to rise against the spring pressure. The barrel locking plunger, together with the barrel locking plunger spring can now be withdrawn from the barrel housing.

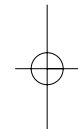
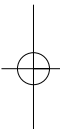

## **MAJOR OVERHAUL OR REPAIR.** **(For a qualified repairer)**

### **Changing the Mainspring and Damper**

The need to change the mainspring will become necessary only after the rifle has been fired many thousands of times. The need to change will become indicated by a gradual loss of pellet velocity not attributable to any other cause, e.g. air leaks, mechanical damage, etc.

#### **Removing the old mainspring**

First ensure that the rifle is not cocked, and then dismantle in the following sequence:

1. Detach the stock assembly by removing the two stock fixing screws front (3383), trigger guard screw front (3387), then the trigger guard screw rear (3385).
2. Remove the trigger unit from the action by tapping out the two body end plug pins (3358).
3. Hold the gun upright with the body end plug resting on a table or workbench, Avoid contact with the safe by bridging it or overhanging the edge of a bench. Press firmly down against the residual spring pressure, and then unscrew the end plug retainer (3364), which also retains the safe detent (2663) and safe detent spring (2664). Ease the pressure off, allowing the gun to rise against the spring pressure. The end plug complete with safe, mainspring and damper can now be withdrawn.
4. Knock the damper (2834) out of the mainspring. If the mainspring shows signs of buckling, a new one, complete with new damper should be fitted. Lubricate the mainspring and damper with WEBLUBE, then insert the damper and push firmly home until its flange is flush with the end of the mainspring. Reassemble in the reverse order. The preceding paragraphs 1 - 4 relate to the necessary dismantling to change the mainspring and damper only. Should it become necessary to dismantle further for a major overhaul, or to replace worn components, adopt the procedure stated in the following paragraphs.

#### **Barrel Assembly Complete.**

To remove the barrel assembly intact, remove the barrel pivot stop screw (2655), then the barrel pivot (2648) complete with the barrel pivot washer (2714).

Slide the assembly away from the breech face until the hidden end of the cocking key (3348) is aligned with the exit hole in the body tube, then pull

3. When ready to fire disengage the safe by pushing it forward with the thumb. Squeeze the trigger when ready to fire

### **ROUTINE CARE.**

1. Do not fire the rifle without a pellet in the barrel. The only time you have to do this is when adjusting the trigger pull.
2. Do not leave the rifle cocked or loaded when not in use. Leaving it cocked will reduce the life of the mainspring.
3. After use, wipe the rifle with an oily rag to prevent corrosion. Use Weblube gun oil.
4. Occasionally apply three or four drops of Weblube gun oil to:
  - a) Barrel pivot (2648).
  - b) Loading lever axis pin (2658).
  - c) Piston skirt. Access is through the loading lever slots in the stock and body tube assembly.
  - d) Piston seal. Access is through the air feed hole in the breech face. Important, serious damage to the piston seal may result if it is excessively lubricated.
  - e) Barrel locking plunger (2989)(fig.2).

Fig. 2 (The stock does not need to be removed to undertake this operation.)



f) Mainsear axis & action pins (3370 & 3371) - very occasionally when stock is removed.

g) Area of body tube contacted by cocking key (3348), adjacent to loading lever slot (fig.3) - very occasionally when stock is removed.

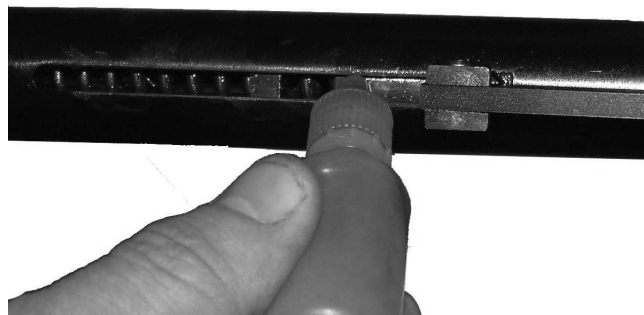

Fig.3

### TRIGGER ADJUSTMENT

The Webley Longbow is fitted with a 2-stage trigger mechanism that is factory set to 0.9kg. (2lbs.)

To adjust these settings the action must be removed from the stock.

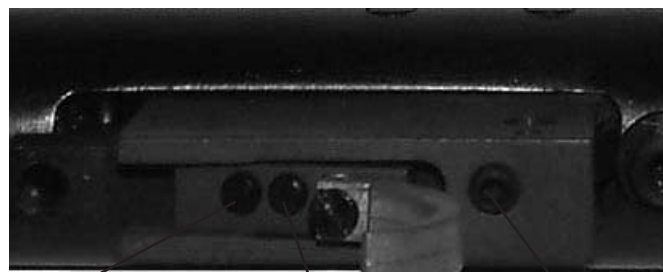

Fig.4.

A) Trigger pull load adjustment screw

B) 2nd stage trigger adjustment screw

C) 1st stage trigger adjustment screw

Screw A adjusts the position and length of the 1st stage trigger pull. Screw B adjusts the position and length of the 2nd stage trigger pull. Screw C adjusts the trigger pull load.

The sear engagement can be viewed through the 6mm hole each side of the trigger cage.

THE OPERATION OF THE SAFETY CATCH IS CONTROLLED BY THE TRIGGER MECHANISM SETTINGS, AFTER ADJUSTING THE TRIGGER MECHANISM ALWAYS CHECK THE SAFETY CATCH ENGAGES CORRECTLY AND THE RIFLE DOES NOT FIRE WHEN THE SAFETY CATCH IS IN THE "SAFE" POSITION. RE-ADJUST THE TRIGGER SETTINGS IF NECESSARY.

When checking the trigger pull always point the rifle towards the ground, even with a pellet in the barrel.

### TECHNICAL SERVICE INSTRUCTIONS

#### Fitting a new breech seal.

Should the breech seal (2657) become damaged or worn, indicated by loss of velocity and air escaping at the breech, a new one should be fitted. To remove the old one, cock the rifle - Apply the safe. Insert a sharp, pointed implement into the annular space occupied by the seal. Pierce the seal and flip it out, taking care not to damage or mark the breech face or the seal recess. (fig.5)

Fig.5



When fitting a new breech seal ensure that its housing is clean and free of any obstructions. The radiused end of the seal must face outwards so as to lie against the breech face of the action. Ensure that the seal is located in its recess as far as it will go all the way round and that the protrusion above the face is about 0.020" (0.5mm).

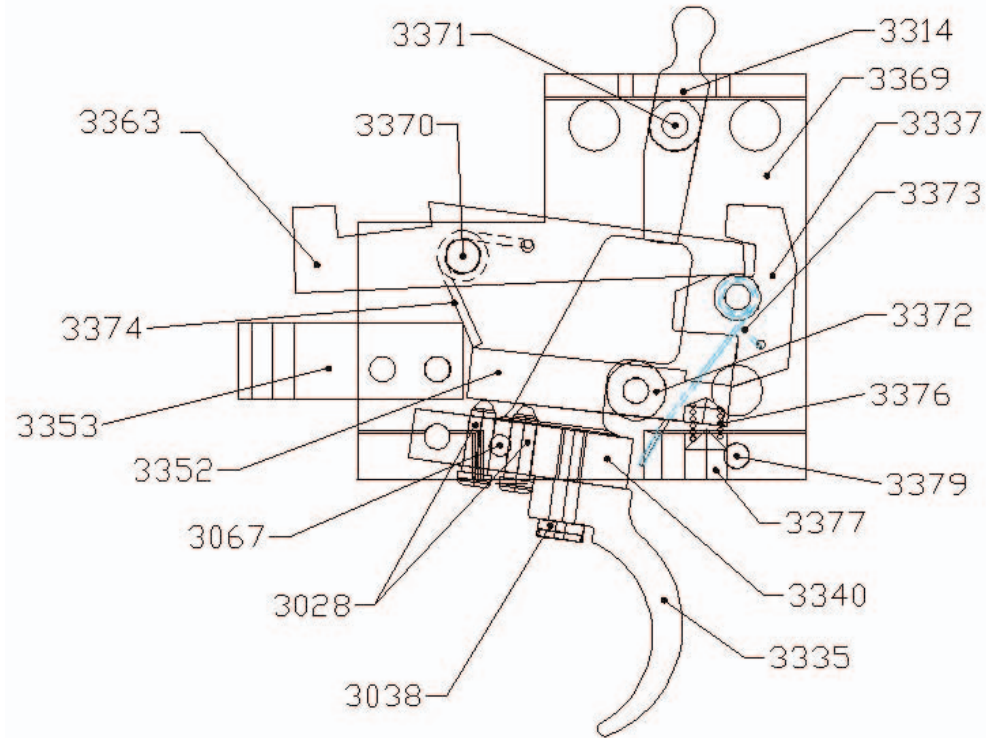
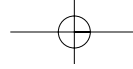

DETAILS OF TRIGGER ASSEMBLY

## SPACE PARTS DIAGRAM AND LIST FOR THE WEBLEY LONGBOW

THIS PAGE MAY BE DETACHED FOR REFERENCE

