



AIR ARMS

USERS HANDBOOK

FOR

SM100, XM100, TM100, NJR100

Pneumatic Air Rifles

Treated with the care that any precision instrument warrants, this air rifle will give you good sport and service over many thousands of shots. Please read this manual before you use your new gun, it contains information to help you keep your gun in top condition.

Always be aware that your actions will be under the scrutiny of other members of the public who may not share your enthusiasm for air rifles. Bad practices promote bad publicity – *remember the Safety Code.*

SAFETY CODE

1. Treat all air-weapons as if loaded.
2. Never point an air-rifle at anyone, even if it is unloaded.
3. Never leave your rifle cocked or loaded
4. Always be sure what lies beyond your target.
5. Always conduct yourself in a sportsmanlike manner.

CAUTION

THE AIR RESERVOIR IS A HIGHLY PRESSURISED UNIT, DO NOT ATTEMPT TO MODIFY OR MACHINE IN ANY WAY.

DO NOT RECHARGE IF THERE ARE LARGE ABRASIONS OR DENTS IN ITS SURFACE.

DO NOT STORE THE RIFLE IN PLACES SUBJECT TO EXCESSIVE HEAT.

DO NOT ATTEMPT TO DISMANTLE WHEN PRESSURISED. SEVERE PERSONAL INJURY MAY RESULT.

ANY UNAUTHORISED DISMANTLING OR MODIFICATION, EXCEPT TO MAKE ADJUSTMENT AS DESCRIBED IN SECTIONS 3 & 4, WILL INVALIDATE YOUR GUARANTEE.

DO NOT RECHARGE BEYOND 190 bar. ONLY USE CLEAN FILTERED AIR, i.e. FOR DIVING/BREATHING APPARATUS.

NEVER USE COMPRESSED OXYGEN.

THIS INFORMATION IS IMPORTANT FOR ANY FUTURE CORRESPONDENCE REGARDING YOUR RIFLE. PLEASE KEEP IN SAFE PLACE.

THE RIFLE No. MUST BE QUOTED WHEN ORDERING SPARE PARTS OR REQUESTING INFORMATION.

RIFLE No.

TEST DATE

ASSEMBLED &
TESTED BY

SET & TESTED
WITH

PELLETS

RIFLE FILLING
PRESSURE

MINIMUM
WORKING
PRESSURE



IMPORTANT INFORMATION

As with any precision mechanism the operation and performance of this weapon will slightly alter as the run in period proceeds. It is advisable during this period to regularly check all settings, particularly the velocity, and make adjustments if necessary.

The cylinder on these weapons is highly pressurised and must be treated with care. Regular visual inspection of the external surface is advised. The cylinder should be removed from

the stock for these inspections. Any dents, or abrasions or corrosion may indicate that the cylinder is in a dangerous condition. If in doubt seek advise from Air Arms.

This advice is of particular importance if the cylinder is to be bedded into the stock with wax or any other substance. It has become evident that this practice does create a potential corrosion area.



INDEX

		Pages
Section 1	General Information	1 - 2
Section 2	Lubrication	3 - 4
Section 3	Maintenance	5
Section 4	Adjustments	6
Section 5	Additional Information	7
Section 6	Parts List	8 - 9
Section 7	Options	10

**ANY UNAUTHORISED DISMANTLING OR MODIFICATION, EXCEPT TO MAKE
ADJUSTMENT AS DESCRIBED IN SECTIONS 3 & 4, WILL INVALIDATE YOUR
GUARANTEE.**



Section 1. GENERAL INFORMATION

1.1 FILLING INSTRUCTIONS

The filling pressure depends on whether your rifle is fitted with a regulator.

Regulated models (TM100 & NJR100) can be filled to the maximum allowable working pressure which is 190 bar (2755 psi). However, a more practical pressure is approx. 160 bar (2320 psi). This will give a useful number of shots, will allow a greater number of refills from your main cylinder and reduce the stress loadings on the rifle reservoir.

Un-regulated models (SM100 & XM100) should not be filled higher than the pressure stated on the front cover of this handbook. Over filling will reduce the velocity of the first number of shots until the correct pressure is attained. Too high a pressure will prevent the gun from firing altogether.

TO FILL:—

If for some reason the rifle reservoir is completely empty the rifle has to be cocked to enable filling.

Do not bend the filling pipe too tightly or reduced operating life will result.

1. Remove end cap (3510, 3520).
Rifles without a snap connector have a plastic *screw off/on* type cap. Rifles with a snap connector have an Aluminium *pull off/push on* type cap.
2. Connect the filling pipe to the gun.
Do not over-tighten the gland nut on SM100.
3. Make sure bleed valve on 'A' clamp body is screwed closed.

The number of shots each fill will produce and the number of refills the air bottle will provide is dependent upon several variables. The following can be generally accepted.

For non-regulated guns, each fill should provide approx. 70 shots in .177 cal. and 70 shots in .22 cal between the recommended filling pressure and the minimum working pressure (stated on the front cover of this handbook).

For regulated guns this figure should be approx. 120 shots in .177 cal. and 170 shots in .22 cal. if filled to 160 bar.

If the 10 lit. AIR ARMS bottle charged to 232 bar is used then approx. 40 refills should be obtainable.

4. Open main valve on filling cylinder slowly, watching the dial on the gauge. Close the valve when gauge indicates the required pressure.
On non-regulated models this pressure should NOT be higher than that stated on the front page of this handbook. (See paragraph above).
(Compression of air generates heat and the rifle reservoir will heat-up as you decant from the filling cylinder. This is quite normal, however filling slowly will minimise heat build-up.)
5. Open bleed valve on 'A' clamp smartly.
6. Detach filling pipe.

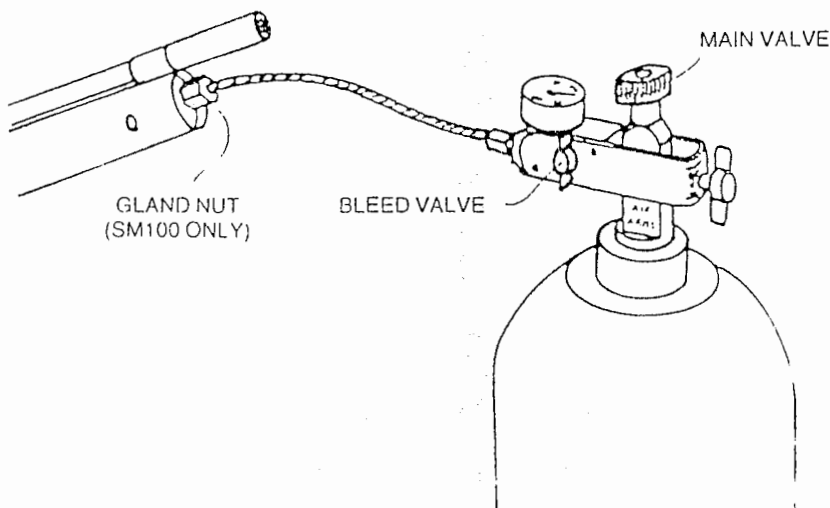



1.2 LOADING INSTRUCTIONS

1. Turn loading bolt anti-clockwise 90°.
2. Draw bolt backwards until trigger clicks into engagement. (When you draw the bolt back the first part of travel is free, the second part under spring pressure).
3. Load pellet into barrel.
5. Turn bolt clockwise 90° into locked position.

1.3 ADDITIONAL INFORMATION

1.3.1 DE-PRESSURISING

An air release valve is provided in the filling valve body. Access is provided through the small hole under the muzzle end of the cylinder. To release air, insert a small allen key and turn the screw anti-clockwise. It is important not to allow the air to be released too quickly or freezing of the internal micro-line filter may result. On regulated models after de-pressurising fire the rifle a few times to release the air stored in the regulator.

By design it is impossible for the release screw to be completely removed through the access hole.

The release valve will re-seal with very little tightening of the screw. Over-tightening will reduce its operational life and cause eventual failure.

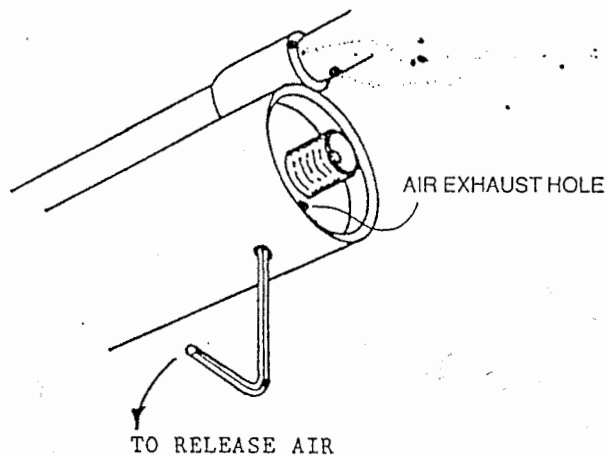



Section 2. LUBRICATION

2.1 GENERAL INFORMATION

Correct lubrication of any piece of precision equipment is essential for a long and trouble free life. The 100 Series of air rifles are no exception to this rule.

Due to their configuration they have relatively light loadings applied to contact areas, this means that the lubrication required is minimal. Over lubrication will actually reduce the performance of the gun.

It is impossible to lay down set rules for lubrication quantities and frequencies because of the varied usages and operating conditions. The most important ingredient is common sense. If the 'feel' of the cocking and firing sequence changes or if the performance suddenly deviates from the norm, this could indicate the need for lubrication.

The use of silicon based lubricants is NOT recommended for moving parts, however they are satisfactory for wiping on exterior surfaces to prevent corrosion.

Some synthetic oils tend to thicken when exposed to atmosphere over an extended period and are thus NOT recommended.

Use a mineral based lightweight oil. Our recommendation is Jenolite Gun Oil.

2.2 SPECIFIC LUBRICATION POINTS

2.2.1 STRIKER ASSEMBLY

The free movement of the striker is vital to the overall performance and consistency of the rifle. This free movement can be effected by over lubrication, use of an oil that is too thick, surface corrosion on the striker and/or tube wall and ingress of dust or foreign particles.

The striker is coated with a PTFE based film which reduces the need for lubrication almost entirely.

A light smear of oil is applied on assembly in the factory and this should be sufficient for a considerable number of shots. The striker should be inspected yearly and lubricated on re-assembly.

2.2.2 LOADING BOLT

The most important indication for lubrication of the loading bolt is the 'feel' of its operation and its appearance. If the operation of the bolt stiffens, feels rough or has a very dry appearance this could indicate the need for lubrication.

Lubricate by moving the bolt repeatedly from closed to open positions putting a drop of oil on each end of the bolt stem. It is not advisable to insert oil into the open end of the bolt housing or through the blanking plug hole as any excess oil will find its way down onto the striker and possibly effect its free travel.

The type and thickness of oil used is not so important as that used for the striker, but a thicker oil will make the operation stiffer. We recommend a lightweight non silicon based gun oil or similar.

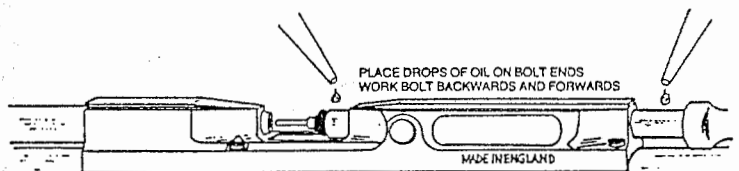

2.2.3 CHASSIS/TRIGGER HOUSING

The sensitivity of the trigger operation can depend on the amount and type of lubrication applied.

A thick oil will make the action sluggish and in the extreme mask the action of the first stage.

Too much oil will eventually run down onto the trigger blade.

Apply the oil by turning the rifle upside down and putting a small drop on each side and to the front edge of the trigger. Allow a few moments for the oil to run into the chassis. If excessive amounts are applied it could find its way onto the striker and effect performance. The recommended oil is a lightweight non silicon based gun oil.

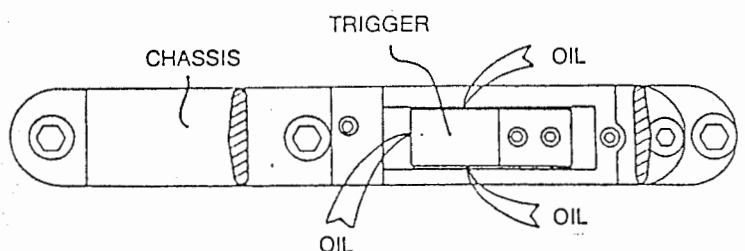



2.2.4 OLYMPIC TRIGGER LUBRICATION

The two most important lubrication points on the Olympic trigger are the sear engagement faces and the top sear to striker contact point. The sear faces can be greased through the inspection hole.

To grease the sear/striker contact point removal of the chassis from the rifle is necessary.

Frequent lubrication with a molybdenum disulphide based grease is recommended for these two points.

Lack of sufficient lubrication on the sear/striker contact point will prevent firing.

Other lubrication points need much less frequent attention and are best carried out by removal of the chassis side plate.

However this plate is a tight fit on the pivot pins and extreme care must be taken on removal to prevent damage to the chassis or sears. Damage caused by misuse or abuse is NOT covered by the warranty.

2.2.5 GENERAL

To assist with the prevention of corrosion inside the rifle reservoir it is advisable to inject a small amount of oil at approx. six monthly intervals.

This is best achieved by putting three or four drops of oil onto the opening of the male snap connector or filling valve body and then filling the rifle as normal.

To prevent corrosion to the inside of the barrel periodically inject a few drops of oil into the chamber end of the barrel and fire the rifle into a piece of rag. DO NOT insert a pellet at the same time.

Alternatively, you may prefer to use the pellet additive 'Accuracy Plus' which has a natural corrosion resistant.

To preserve the polished finish on the external surfaces, lightly wipe over with a soft oily rag. This should be done immediately after each time the rifle is used.

If the use is infrequent or if the rifle is to be stored away, a much heavier film should be applied.

Avoid storing the rifle in a gun bag. Any dampness present will be sealed in and accelerate corrosion.

Occasionally remove the bolt housing blanking plug, lay the rifle on its side and insert a drop of oil. DO NOT put more, any excess will find its way

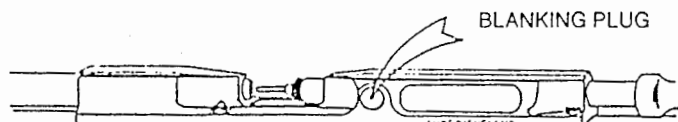
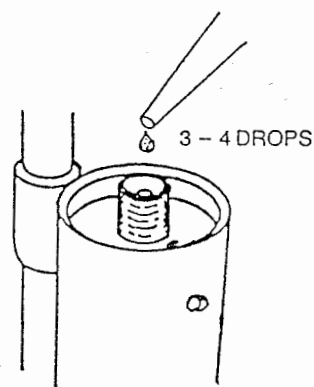
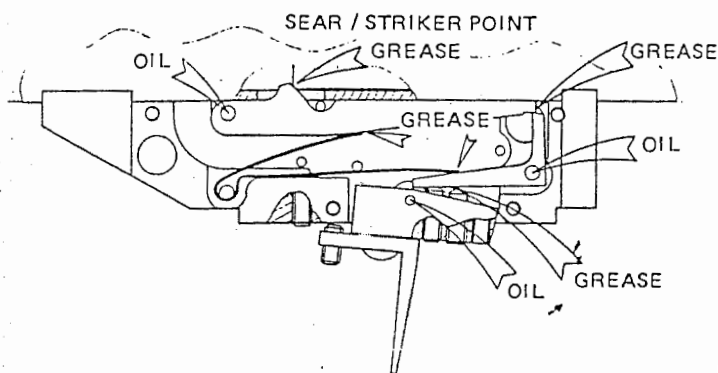



Section 3. MAINTENANCE

3.1 GENERAL INFORMATION

Apart from lubrication procedures the maintenance required should be minimal.

3.2 BARREL SEALS

Occasionally inspect the barrel seals for damage (1320, 1325 & 1330).

Should replacement be needed, carefully cut through them with a sharp knife and replace, fitting the large seal first followed by the small seal.

3.3 FIXING SCREWS

Check the tightness of all fixing bolts and screws. **DO NOT OVERTIGHTEN.** Unlike a spring rifle, threads do not have to be tightened to account for recoil.

Particular attention should be paid to fact that the valve bodies inside the main cylinder tube are made of aluminium and although of high tensile quality, over-tightening may cause threads to be stripped. Caution is advised.

3.4 MUZZLE ENERGY

The muzzle energy has been set to conform to statutory requirements using the pellets stated on the front page of this handbook. If any other pellets are used the settings may have to be altered.

Pellets vary so much, not only between manufacturers but even types from the same manufacturer, that it is impossible to guarantee that all of the pellets available on the market will result in the legal use of the rifle.

It is therefore essential to check the muzzle energy if it is intended to use any other than the stated pellet.

Adjustment is provided should it be found to be necessary.

If adjustments are made the rifle must be checked throughout its entire range using a reliable chronograph over several charges.

A few words of warning!

- It is extremely easy to upset the fine balance of settings that control the overall performance of the rifle. Consistency is dependent upon the right balance between spring pressures, valve openings, striker travel and transfer port size. Alterations to any one of these without consideration for the others will make the rifle effectively unusable.
- It is a very serious offence to be in possession of a firearm without an appropriate licence. In the eyes of the law an air rifle even marginally over the limit is classed as a firearm, for which a Fire Arms Certificate is required.

To make adjustments:—

- Remove action from stock (the trigger guard must be removed first).
- Remove blanking plug (1095) and locking screw (1121).
- Using same allen key turn adjuster clockwise to increase and anti-clockwise to reduce pellet velocity.
There should never be need to move the adjuster more than half a turn either way to get the desired results. More than this will likely upset the balance mentioned in note a).
- Replace the locking screw and check the velocity throughout the charge.

A tip! For non-regulated guns, if you fill the rifle to approx. 125 bar and set the velocity to 5–10 fps below the limit for the pellet you wish to use, the setting should not be too far out.

3.5 MUZZLE END & MODERATOR FITTING

On fitting, the opposing fixing screws must be tightened equally or the barrel end will be biased thus altering the zero point. These screws **DO NOT** need to be very tight.

There needs to be a 0.25mm gap between the muzzle end or moderator and the barrel guide.

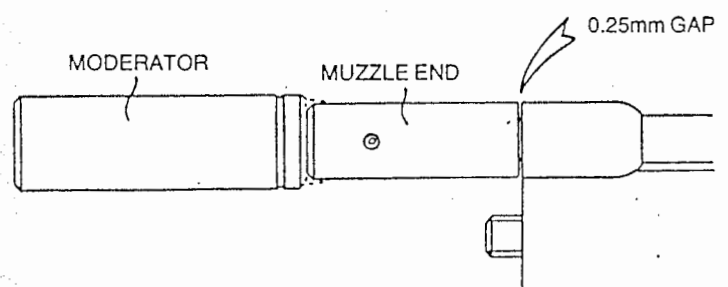



Section 4. ADJUSTMENTS

4.1 TRIGGER ADJUSTMENT

The trigger has adjustment for travel and weight on both stages. Sear engagement is determined by 2nd stage travel.

Too much or too little weight applied to the second stage will cause the operation to be intermittent, this obviously should be avoided.

Extremely small 2nd stage travel may cause the rifle to fire at the slightest touch.

A reasonable starting point is to cock the mechanism (without a pellet) and adjust the 2nd stage travel screw, clockwise, very slowly until the rifle fires. Now adjust anti-clockwise one turn.

The 1st stage travel can be adjusted out completely if desired, this in effect will give a single stage trigger.

It is possible to increase the weight of the 1st stage and decrease the weight of the 2nd stage to a point where the 1st stage will overcome the 2nd stage.

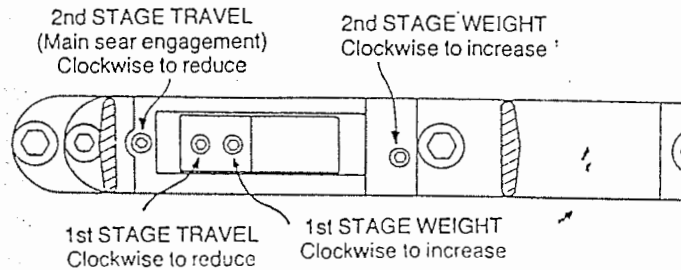

4.2 OLYMPIC TRIGGER ADJUSTMENT

The Olympic mechanism is intended to provide a trigger of 'match' quality. It is able to be adjusted to much lower pull weights and finer sear engagements than the standard trigger.

It is possible to fit this trigger to standard rifles but will involve complete resetting to the internals. It is therefore advised that this fitting be carried out at the factory.

Adjustment of screw 'A' increases or decreases 'weight of pull'.

The range of settings can be altered by moving screw 'D' to position 'E'.

When in position 'D' the range is between 3 and 6 oz.

When in position 'E' the range is between 6 and 11 oz.

When adjusting trigger start by positioning the blade to the desired position.

Adjustment is provided for forward, back and radial movement by releasing the locking screw, positioning blade and relocking screw.

Then adjust screw 'A' anticlockwise to the minimum pull weight setting.

Set trigger 'forward stop' position with screw 'B'. Cock mechanism (see section 1.2, page 2) WITHOUT loading pellet. (If mechanism won't cock turn screws 'C' & 'D' anticlockwise 1 or 2 turns and retry)

Adjust screw 'C' clockwise until engagement is

(This can be observed through the inspection hole)

Pull trigger slowly watching the sears disengage. (If the gun fires without any 2nd stage operation then adjust screw 'D' clockwise half turn, re-cock the gun and retry).

When you have proper 1st and 2nd stage operation, final minor adjustments can be made to obtain your exact preference.

Finally adjust screw 'A' clockwise to the desired 'weight of pull' setting. (If the desired 'weight of pull' is close to 6 oz, move screw 'D' to position 'E'. This will reduce the spring loads on the sears and improve operation.)

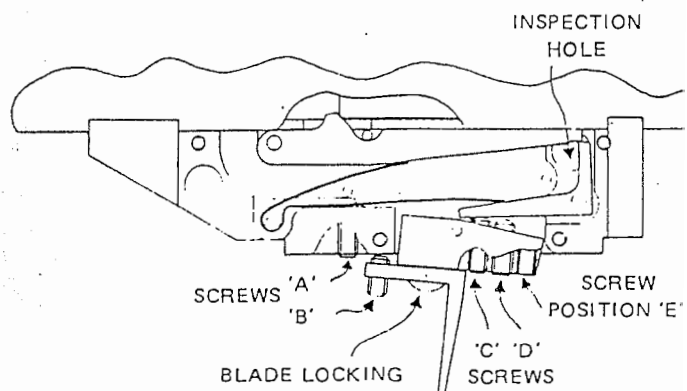



Section 5. USEFUL INFORMATION

5.1

All 100 Series models are fitted with choked barrels, we therefore advise that plastic skirted pellets should NOT be used.

5.2

The .22 cal barrel is best suited to 5.5 mm diameter pellets.

5.3

It is important that the stock screws are maintained at a constant torque. If they are loosened or tightened to a different torque it is possible that the rifle will need re-sighting.

5.4

Muzzle energy is calculated from velocity using the following formula:—

$$\text{muzzle energy} \frac{V^2 \times W}{450240}$$

where V — velocity in ft./sec.

W — weight of pellet in grains.

1 gram — 15.432 grains.

The current legal muzzle energy limit is 12 ft./lbs. for air-rifles.

5.5

When the pressure inside the rifle reservoir goes below the regulator pressure the remaining air will escape through the barrel. To prevent total loss, cock the rifle and refill.

5.6

To achieve and maintain the best possible accuracy it is important to select and grade pellets. At least, they should be checked for roundness and lack of distortion, particularly to the skirt. Ultimately they should also be graded for weight. Sizing of the pellet is not advised as this is done automatically on insertion into the breach.

A new trend is the use of a pellet coating additive, 'Accuracy Plus' which also has the added advantage of lubricating the barrel.

5.7

All **AIR ARMS** 100 Series air rifles have a 12 months' parts and labour warranty from the date of purchase. This warranty does not cover items of normal wear and tear or damage caused by misuse or improper handling. It also does not cover resetting brought about by incorrect adjustments made outside the manufacturers premises.

In the event of any problems contact the place of purchase in the first instance. If they are unable to assist then call our service department and you will be advised accordingly. All genuine warranty claims and service work is carried out immediately and sent by return.

Allow for a reasonable settling in period before assuming a fault.



SPARE PARTS LIST, 100 SERIES

Part No.	Description	Part No.	Description
AA1036	Firing Valve Pot	AA1901	Straight Trigger Blade
AA1045	Firing Valve Spring	AA1902	Trigger Blade Screw
AA1065	Secondary Seal	AA3010	Filling Valve Body
AA1076	Ring Clamp	AA3011	Male Snap Connector
AA1090	Rear Plug	AA3012	Dust Seal
AA1095	Rear Plug Bung	AA3013	Air Release Valve
AA1100	Striker	AA3014	Air Release Screw
AA1110	Striker Adjuster	AA3015	Barrel Support
AA1115	Spring Plate	AA3016	Screw
AA1120	Spring Adjuster	AA3025	Bonded Seal
AA1121	Locking Screw	AA3026	O Ring
AA1125	Locking Ball	AA3035	Filter
AA1130	Locking Screw	AA3036	Regulator
AA1135	Main Spring	AA3040	Filling Valve Spring
AA1140	Striker Screw	AA3050	Filling Valve
AA1145	Chassis	AA3057	Firing Valve (Unregulated)
AA1150	Screw	AA3057R	Firing Valve (Regulated)
AA1155	Screw	AA3060	Firing Valve Spacer (Unregulated)
AA1170	Main Sear	AA3080	Firing Valve Body
AA1175	Pivot Pin	AA3085	Reservoir Tube
AA1180	Circlip	AA3136	Spring Damper
AA1185	Pin	AA3145	Olympic Trigger Chassis Plates
AA1190	Spring	AA3170	Olympic Trigger Top Sear
AA1195	Screw	AA3215	Olympic Trigger Secondary Sear
AA1200	Screw	AA3220	Olympic Trigger Spring
AA1205	Curved Blade Trigger	AA3225	Olympic Trigger Large Pin
AA1215	Trigger Sear	AA3230	Olympic Trigger Small Pin
AA1220	Trigger Bush	AA3235	Olympic Trigger Adjuster Screw
AA1235	Screw	AA3265	Barrel Bush
AA1240	Trigger Guard	AA3271	Bolt Housing/Barrel Assy .177 Cal.
AA1250	Screw	AA3272	Bolt Housing/Barrel Assy .22 Cal.
AA1273	Screw	AA3285	Transfer Port Bush (Unregulated)
AA1275	Bolt Housing Bung	AA3285R	Transfer Port Bush (Regulated)
AA1315	Loading Bolt .177 cal.	AA3315	Lever Bolt .177 Cal.
AA1316	Loading Bolt .22 cal.	AA3316	Lever Bolt .22 Cal.
AA1320	O Ring	AA3500	Sound Moderator
AA1325	O Ring	AA3510	End Cap
AA1330	O Ring	AA3511	O Ring
AA1331	O Ring	AA3520	Plastic Dust Cap
AA1335	O Ring Spacer	AA3530	Muzzle End
AA1340	Bolt Screw	AA3712	SM100 Front Stock Screw
AA1505	Screw	AA3730	SM100 Rear Stock Screw
AA1712	TM100 Front Stock Screw	AA3735	XM100 Stock Screw
AA1715	Brass Washer	AA3740	NJR100 Front Stock Screw
AA1716	Plain Washer	AA3750	NJR100 Rear Stock Screw
AA1717	Star Washer	AA3800	Screw
AA1730	TM100 Rear Stock Screw	AA3810	Primary Seal
AA1740	Adjuster Top Block	AA3820	Female Snap Connector
AA1750	Adjuster Bottom Block	AA3900	Olympic Trigger Body
AA1760	Adjuster Clamp Plate	AA3901	Olympic Trigger Blade
AA1770	Adjuster Pillar	AA3902	Olympic Trigger Stop Screw
AA1780	Adjuster Screw Cup		
AA1785	Adjuster Locking Screw		
AA1790	Screw		
AA1800	Screw		
AA1900	Straight Blade Trigger Body		

NOT ALL PARTS LISTED ARE FITTED TO ALL MODELS
PART No. AA1740 AA1800 FITTED TO ADJUSTABLE STOCK MODELS
ONLY
PART No. AA1900 USES SAME SPRING & SCREWS AS AA1205



AIR ARMS SERIES 100 RIFLES OPTIONS SHEET

	SM100	XM1100	TM100	NJR100
4.5 Cal. (.177)	O	O	O	O
5.5 Cal. (.22)	O	O	O	O
Quick Release Snap Connector	F & X	S	S	S
Aluminium End Cover	F & X	S	S	S
Plastic Dust Cap	S			
Muzzle End	S	S	S	S
Sound Moderator	F & X	F & X	F & X	F & X
Lever Type Loading Bolt	F & X	F & X	F & X	S
Knob Type Loading Bolt	S	S	S	Q & X
Standard Valve Assembly	S	S		
Regulator Valve Assembly	F	F	S	S
Curved Sporting Trigger	S	S	O & X	O & X
Adjustable Straight Blade Trigger	F & X	F & X	S	S
Chequered Beech Sporting Stock	S			
Chequered 2* Walnut Sporting Stock		S		
Stippled Walnut Target Stock			S	
Stippled Thumb-hole Walnut Stock				S
Adjustable Butt Pad			S	S
Adjustable Cheek-piece			S	S
Adjustable Fore-end				S

Key:- S = Standard Fitting
 F = Factory Fitted Option at EXTRA COST
 O = Factory Fitted Option at NO EXTRA COST
 X = Available as Spare Part, Customer Fitted